

## Features:

- Excitation system: self-excited (AREP and PMG are optional)
- ATS (automatic transfer switch) receptacle
- Lockable battery isolator switch
- Stainless galvanized zinc plates with strong corrosion resistance
- Vibration isolators between the engine/alternator and base frame
- Integrated wiring design
- Base fuel tank for at least 8 hours running
- Equipped with an industrial muffler
- Engine oil pump
- 50 C radiator
- Top lifting and steel base frame with forklift holes
- Drainage for fuel tank
- Complete protection functions and safety labels
- IP54 (soundproof sets), IP56 (control system)
- Water jacket preheater, oil heater and double air cleaner, etc. are available.



### Output Ratings

Generating Set Model	Prime	Standby
X125C6/S	140kVA/112kW	154kVA/123kW

Ratings at 0.8 power factor.

### Ratings and Performance Data

<b>Engine Make &amp; Model:</b>	6BTAA5.9-G2	
<b>Alternator Model:</b>	UCI274D	
<b>Alternator Brand:</b>	STAMFORD	
<b>Control System:</b>	PLC-920 / PLC-7420	
<b>Noise Level@7m:</b>	63.9	
<b>Frequency &amp; Phase:</b>	60Hz & 3PH	
<b>Engine Speed: RPM</b>	1800	
<b>Structure Type:</b>	X125C6	A
	X125C6S	R
<b>Fuel Tank Capacity: L</b>	X125C6	225
	X125C6S	300
<b>Fuel Consumption: l/hr (100% Load)</b>	Prime	30
	Standby	34

### Dimensions and Weights

Generating Set Model	Length (L) mm (in)	Width (W) mm (in)	Height (H) mm (in)	Dry kg (lb)
X125C6	2204	949	1540	1253
X125C6S	3312	1150	1831	2078

Dry = With Lube Oil      Wet = With Lube Oil and Coolant

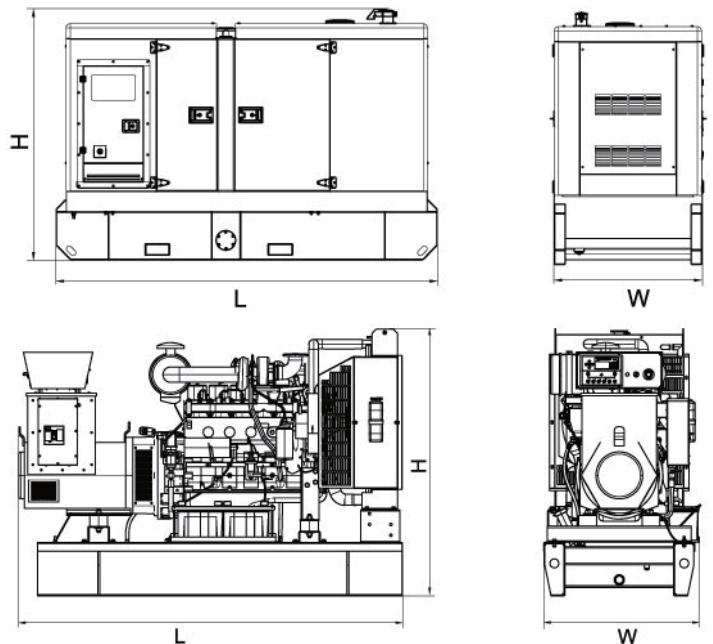

Also available in the following voltages: 415/240V-380/220V-220/127V-200/115V;

ESP: Standby Power Standby duty, operation under variable load, without over load;

PRP: Prime Power-Continuous duty operation, under variable load 24/24h-10% over load permissible 1 hour/12 hours;

The data is only for your reference but not for use of sales.

M: Mechanical speed governor, E/ECU: Electronic speed governor;

NA: Naturally aspirated, TC: Turbocharged, TCA: Turbocharged and air-air aftercooled. TCW: Water-cooled Turbocharged;

The weights are approximate and without fuel.

## Engine model: 6BTAA5.9-G2

### Typical engine data

Net weight	kg	411
Rotate part instantaneous inertia _ without flywheel	kg.m <sup>2</sup>	0.25
Distance between gravity center and rear surface of cylinder block	mm	544
Distance between gravity center and center line above of crankshaft	mm	155

### Engine installation

Static bent torque permitted—rear surface of cylinder block	N.m	1356
Static bent torque permitted—front surface of cylinder block	N.m	435
Static bent torque permitted—flank surface of cylinder block	N.m	365

### Exhaust system

Max. back pressure	mmHg	76
Diameter of exhaust pipe recommended	mm	75

### Air intake system

Max. air intake resistance		
Dirty filter	mmH <sub>2</sub> O	635
Normal air cleaner and clean filter	mmH <sub>2</sub> O	254
Heavy duty cleaner and clean filter	mmH <sub>2</sub> O	381
Diameter of intake pipe recommended	mm	100

### Lubrication system

Normal oil pressure range		
Low idle	kPa	207
Rated speed	kPa	345
Max. oil temperature permitted in oil pan	°C	121
Oil pan capacity (Max _ Min)	L	14.2_12.3
Lubrication system Min. capacity (oil pan + oil filter)	L	16.4
Usage inclining degree permitted (any direction)	°	40

### Fuel system

Fuel injection pump model	PB pump _ GAC governor / BYC ASIMCO	
Max. fuel input resistance of transfer pump	mmHg	102
Max. overflow fuel resistance at overflow pipe of injector	mmHg	254
Total fuel overflow amount	L/h	30

### Cooling system

Coolant capacity-engine only	L	9.9
Max. coolant cycling resistance exterior engine	kPa	28
Thermostat adjusting temperature (range)	°C	82_95
Min. opening pressure of radiator cap	kPa	69
Max. coolant temperature permitted _ Standby Power/Base output Power	°C	104/100

### Electric system

Starter	12V	24V
Battery charging system	63A	40A
Max. starting circuit resistance	0.00075Ω	0.002Ω
Min. battery capacity _ -12°C (CCA: Cold Cranking Ampere)	800CCA	400CCA

### Technical data \_ under standard fuel delivery rate FR 9266-03

	Base output Power	Standby Power
Engine speed _ RPM	1500	1500
Output Power _ kW	120	130
Torque _ Nm	764	828
Low idle _ RPM	750-850	750-850
Friction energy output _ kW	12.7	12.7
Piston speed _ m/s	6.0	6.0
Engine coolant flow _ L/sec	2.0	2.0
Air intake flow _ L/sec	135	145
Exhaust flow _ L/sec	293	324
Exhaust temperature _ °C	481	495
Environment energy output _ kW	N/A	N/A
Coolant energy output _ kW	45	50
Fuel energy output _ kW	N/A	N/A

## Alternator model: UC1274D

CONTROL SYSTEM	SEPARATELY EXCITED BY P.M.G.		
A.V.R.	MX321	MX341	
VOLTAGE REGULATION	± 0.5 %	± 1.0 %	With 4% ENGINE GOVERNING
SUSTAINED SHORT CIRCUIT	REFER TO SHORT CIRCUIT DECREMENT CURVES (page 7)		

CONTROL SYSTEM	SELF EXCITED		
A.V.R.	SX460	AS440	
VOLTAGE REGULATION	± 1.0 %	± 1.0 %	With 4% ENGINE GOVERNING
SUSTAINED SHORT CIRCUIT	SERIES 4 CONTROL DOES NOT SUSTAIN A SHORT CIRCUIT CURRENT		

INSULATION SYSTEM	CLASS H		
PROTECTION	IP23		
RATED POWER FACTOR	0.8		
STATOR WINDING	DOUBLE LAYER CONCENTRIC		
WINDING PITCH	TWO THIRDS		
WINDING LEADS	12		
STATOR WDG. RESISTANCE	0.044 Ohms PER PHASE AT 22°C SERIES STAR CONNECTED		
ROTOR WDG. RESISTANCE	1.26 Ohms at 22°C		
EXCITER STATOR RESISTANCE	20 Ohms at 22°C		
EXCITER ROTOR RESISTANCE	0.091 Ohms PER PHASE AT 22°C		
R.F.I. SUPPRESSION	BS EN 61000-6-2 & BS EN 61000-6-4, VDE 0875G, VDE 0875N. refer to factory for others		
WAVEFORM DISTORTION	NO LOAD < 1.5% NON-DISTORTING BALANCED LINEAR LOAD < 5.0%		
MAXIMUM OVERSPEED	2250 Rev/Min		
BEARING DRIVE END	BALL. 6315-2RS (ISO)		
BEARING NON-DRIVE END	BALL. 6310-2RS (ISO)		

	1 BEARING	2 BEARING
WEIGHT COMP. GENERATOR	431 kg	450 kg
WEIGHT WOUND STATOR	141 kg	141 kg
WEIGHT WOUND ROTOR	149.37 kg	138.41 kg
WR <sup>2</sup> INERTIA	1.1962 kgm <sup>2</sup>	1.1455 kgm <sup>2</sup>
SHIPPING WEIGHTS in a crate	458 kg	476 kg
PACKING CRATE SIZE	105 x 67 x 103(cm)	105 x 67 x 103(cm)

	50 Hz				60 Hz			
	THF<2%				TIF<50			
	0.514 m <sup>3</sup> /sec 1090 cfm				0.617 m <sup>3</sup> /sec 1308 cfm			
TELEPHONE INTERFERENCE								
COOLING AIR								
VOLTAGE SERIES STAR	380/220	400/231	415/240	440/254	416/240	440/254	460/266	480/277
VOLTAGE PARALLEL STAR	190/110	200/115	208/120	220/127	208/120	220/127	230/133	240/138
VOLTAGE SERIES DELTA	220/110	230/115	240/120	254/127	240/120	254/127	266/133	277/138
kVA BASE RATING FOR REACTANCE VALUES	114	120	114	N/A	131.3	137.5	137.5	146.3
X <sub>d</sub> DIR. AXIS SYNCHRONOUS	2.17	2.06	1.82	-	2.52	2.36	2.16	2.11
X' <sub>d</sub> DIR. AXIS TRANSIENT	0.18	0.18	0.16	-	0.21	0.20	0.18	0.17
X'' <sub>d</sub> DIR. AXIS SUBTRANSIENT	0.12	0.11	0.10	-	0.15	0.14	0.13	0.12
X <sub>q</sub> QUAD. AXIS REACTANCE	1.39	1.32	1.17	-	1.49	1.39	1.28	1.25
X'' <sub>q</sub> QUAD. AXIS SUBTRANSIENT	0.16	0.16	0.14	-	0.21	0.20	0.18	0.17
X <sub>L</sub> LEAKAGE REACTANCE	0.07	0.06	0.06	-	0.07	0.07	0.06	0.06
X <sub>2</sub> NEGATIVE SEQUENCE	0.14	0.13	0.12	-	0.17	0.16	0.15	0.14
X <sub>0</sub> ZERO SEQUENCE	0.09	0.08	0.07	-	0.10	0.09	0.09	0.08

REACTANCES ARE SATURATED		VALUES ARE PER UNIT AT RATING AND VOLTAGE INDICATED	
T' <sub>d</sub> TRANSIENT TIME CONST.	0.031 s		
T'' <sub>d</sub> SUB-TRANSTIME CONST.	0.01 s		
T' <sub>do</sub> O.C. FIELD TIME CONST.	0.85 s		
T <sub>a</sub> ARMATURE TIME CONST.	0.0073 s		
SHORT CIRCUIT RATIO	1/X <sub>d</sub>		